

Direct Mount Temperature Switch



Model TSB

- Limit Switch for Critical Temperature
- Operate Alarms or Shutdown Equipment
- SPDT Snap-Acting Switch
- Fits Most Engine Applications

Description

The TSB switch is a direct mount switch for temperature sensing. It has one limit contact that can be used to activate an alarm, actuate indicator lights or shut down equipment.

The construction of this instrument is the same as our time-proven Swichgage®. A precision machined brass mounting plate and port captures a high quality stamped beryllium copper diaphragm. The single-pole, double-throw (SPDT) snap switch is operated directly from the diaphragm, for quick acting and positive switching. Trip point is factory preset according to your specifications.

Housing is weather sealed to prevent entry of moisture, dust, etc. A glass-filled nylon terminal block with quick-screw terminal connections gives the TSB switch a real advantage in industrial engine applications. The TSB is ideal when reading is not desired, but temperature is critical to operational efficiency.

Intended for use in general purpose non-classified areas.

Applications

- Engine Coolant
- Irrigation Systems
- Compressors
- Oil Field Systems
- Engine Lubrication
- Construction equipment
- Mobile Equipment
- Marine Engines
- Generators
- Electric Motors

Features

- Fits most engine applications
- SPDT snap-switch
- Activates indicator lights, alarms or shut down equipment
- Time-proven Swichgage construction
- Easy wiring terminal block
- Steel housing specially coated to resist corrosion
- Trip point is factory preset to your specifications (minimum quantities apply)

Specifications

Housing: Plated steel.

Connections: Popular NPT and metric (specify).

Diaphragm: Formed beryllium copper (heat treated).

Sensing Bulb: Copper.

Terminal Block: Three # 4-40 screws.

Accuracy: See chart on page 2.

Contact Rating: SPDT 3 A @ 30 VDC inductive.

Maximum Temperature: 325°F (163°C).

Factory Trip Point Setting: 210°F (99°C) Rising.

Contact: Operates on rising temperature only.

Shipping Weight: 10 oz (0.31 kg).

Shipping Dimensions: 4-3/4 x 4-3/4 x 2-5/8 in. (121 x 121 x 67 mm).

NOTE: No customer replacement parts.

**Products covered by this bulletin comply with EMC Council directive 89/336/EEC regarding electromagnetic compatibility except as noted.

Dimensions

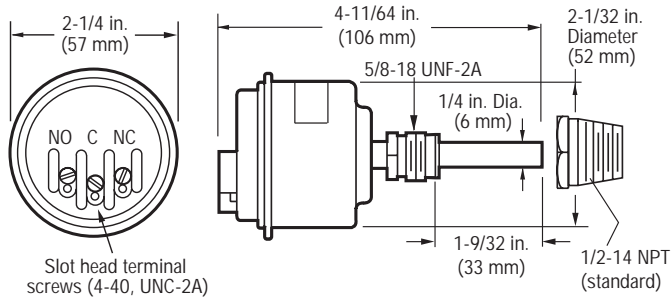

How to Order

To order the TSB model use the diagram below.

TSB – R230 – 3/8

Standard Switch Trip Point	
Specify trip point value. Example: TSB-R200	
Standard Switch Trip Point Values (rising)*	Accuracy
R165 = 165°F (74°C)	165–210°F ±5°F (±2.7°C) Water/glycol 10% used for setpoint
R180 = 180°F (82°C)	
R200 = 200°F (93°C)	
R205 = 205°F (96°C)	
R210 = 210°F (99°C)	
R220 = 220°F (104°C)	215–230°F ±7°F (±3.8°C) 240–250°F ±10°F (±6.5°C) Heat transfer fluid used for setpoint (276 viscosity @ 100°F)
R225 = 225°F (107°C)	
R230 = 230°F (110°C)	
R240 = 240°F (116°C)	
R250 = 250°F (121°C)	
* Non standard trip points require a minimum quantity order. Trip point must be in 5°F increments between 165–250°F (74–121°C).	
Switch Reset Differential	±15°F (±8.3°C)
Switch Repeatability	±3°F (1.7°C)

Connection Size	
Blank = 1/2-14 NPT**	10-05-0131**
1/4 = 1/4-18 NPT	10-05-0167
3/8 = 3/8-18 NPT	10-05-0069
5/8 = 5/8-18 UNF	10-05-0068
3/4 = 3/4-14 NPT	10-05-0105
7/8 = 7/8-9 UNC	10-05-0093
3/8B = 3/8-19 BSPT	10-05-0284
1/2B = 1/2 BSPT	10-05-0330
M14 = 14 mm x 1.5 †	10-05-0104 †
M16 = 16 mm x 1.5 †	10-05-0514 †
M18 = 18 mm x 1.5 †	10-05-0399 †
M20 = 20 mm x 1.5 †	10-05-0670 †
M22 = 22 mm x 1.5 †	10-05-0606 †
M24 = 24 mm x 1.5 †	10-05-0907 †
** Standard connection. † Includes copper seal.	

Installation Instructions

Mounting

1. The TSB can be mounted in horizontal or vertical angles (**do not mount the switch facing down**).

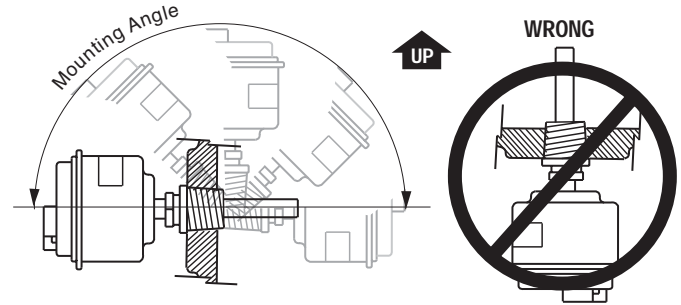

2. Install the TSB switch in the engine water jacket location recommended by the engine manufacturer.
3. Install the appropriate adapter nut into the engine water jacket. Use thread sealant such as Teflon® tape as necessary.
4. Insert the sensing bulb through the adapter nut. The sensing bulb must be fully immersed in coolant/liquid flow so liquid flows across the sensing bulb.
5. Tighten the 5/8-18 UNF-2A compression nut to complete a liquid tight seal.

Wiring

CAUTION: DISCONNECT Electrical Power before wiring.

1. See wiring schematic below.
Switch contacts are shown with no temperature applied to the TSB switch.
2. A spade (forked) terminal is recommended for all TSB switch connections.
3. Complete the wiring operation making sure the voltage and current requirements are within the TSB switch electrical rating.

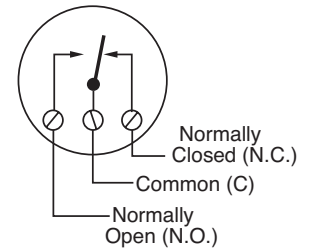

Teflon is a trademark of Dupont.

Warranty

A limited warranty on materials and workmanship is given with this FW Murphy product. A copy of the warranty may be viewed or printed by going to www.fwmurphy.com/support/warranty.htm



Murphy摩菲仪表授权经销商

信德迈科技(北京)有限公司 CNMEC Technology
地址：北京市朝阳区胜古中路2号金基业大厦201室
电话：010- 8428 2935,13910962635
Http://www.cnmec.com Email: sales@cnmec.biz
传真：010-8428 8762