

Pneumatic Valves for Fuel Gas Shutoff

Models M2582-P and M5180-P

The MS582-P and M5180-P are pneumatically controlled fuel shutoff valves that open and close automatically or semi-automatically. The pneumatic control pressure can be air, oil or gas. A manual lever aids in opening the valve when control pressure is insufficient. A gas escape vent, when properly vented and maintained, releases trapped gas from the valve after shutoff. Basic operation is:

Automatic: As the control pressure/vacuum increase the valve will open. When the control pressure/vacuum decreases, the valve will close.

Semi-Automatic: If the control pressure/vacuum is too low and the valve does not open automatically, it can be opened manually by lifting the built-in lever arm and setting the latch. The latch resets automatically when control pressure rises enough to release it.

M2582-P is for 1-inch (25 mm) gas lines. It automatically opens at 5 psi (35kPa) [0.34 bar] and fully opens the seat at 15 psi (103 kPa) [1.02 bar]. The valve can be manually opened with the lever and latch against inlet pressure of 80 psi (552 kPa) [5.52 bar]. The latch will release after pilot pressure reaches 11 psi (17kPa) [.17 bar].

M5180-P is for 2-inch (52 mm) gas lines. It automatically opens at 5 psi (35kPa) [0.34 bar] and fully opens the seat at 15 psi (21 kPa) [.21 bar]. The valve can be manually opened with the lever and latch against inlet pressure of 100 psi (689 kPa) [6.89 bar]. The latch will release after pilot pressure reaches 11 psi (17kPa) [.17 bar].



Dimensions

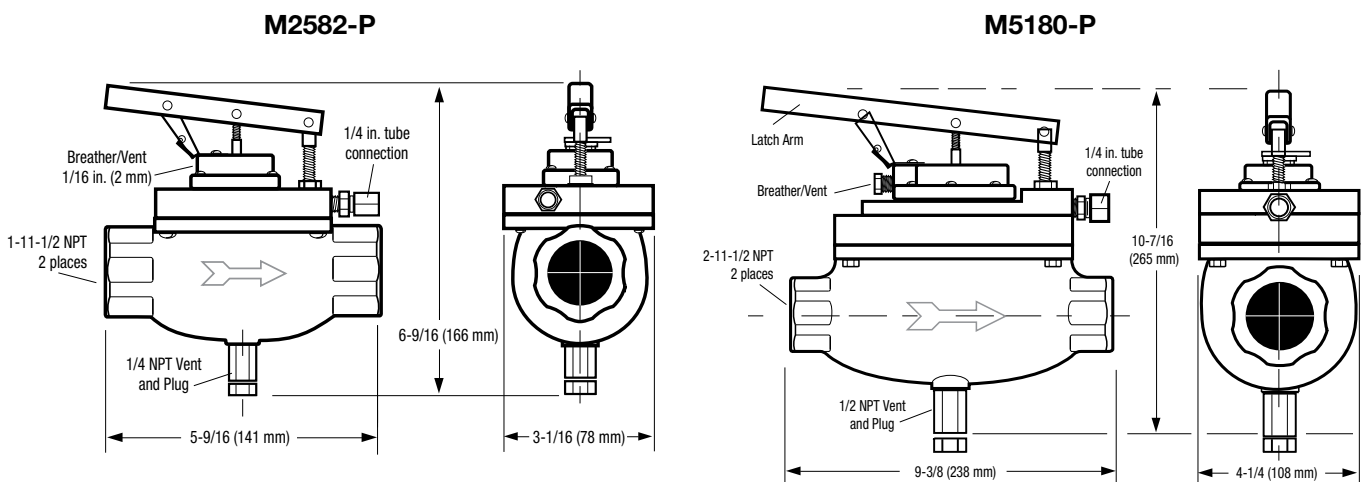

M2582-P / M5180-P: Latch Arm, thumb operated opening latch requires 2.5 psi, (0.17 bar) to release cocking latch.

M2582-P: Control pressure fitting, 1/4 in. (6 mm) tube connection; 15 psi. (103 kPa) [0.21 bar] min., 75 psi. (517 kPa) [5.17 bar] max.

M5180-P: Control pressure fitting, 1/4 in. (6 mm) tube connection; 15 psi. (103 kPa) [0.21 bar] min., 80 psi. (552 kPa) [5.52 bar] max.

M5180-P: Breather vent fitting can be swapped with the control pressure fitting to convert to vacuum control.

M2582-P Flow Characteristics Laboratory Test

Specifications

Valve body: Sandcast aluminum (alodined for corrosion resistance). Optional steel body available on M5180-P models only.

Valve seat: Buna-N

Valve Inlet Pressure (maximum):

M2582-P: 80 psi (552 kPa) [5.52 bar]

M5180-P: 100 psi (689 kPa) [6.89 bar]

Parts exposed to gas line flow:

M2582-P:

- Aluminum
 - Buna-N
 - 302, 303 and 17-7 PH stainless steel
- M5180-P:
- Aluminum (steel optional)
 - Buna-N
 - 302, 303, 304 and 416 stainless steel

Control diaphragm: Flexweave polyester fabric and Buna-N elastomer

Control pressure (maximum):

M2582-P: 75 psi (517 kPa) [2.55 bar]

M5180-P: 80 psi (552 kPa) [5.52 bar]

Shipping Weights:

M2582-P: 5 lbs 10 oz (2.55 kg)

M5180-P: 9 lbs 2 oz (4.16 kg)

With steel body option: 25 lbs (11.34 kg)

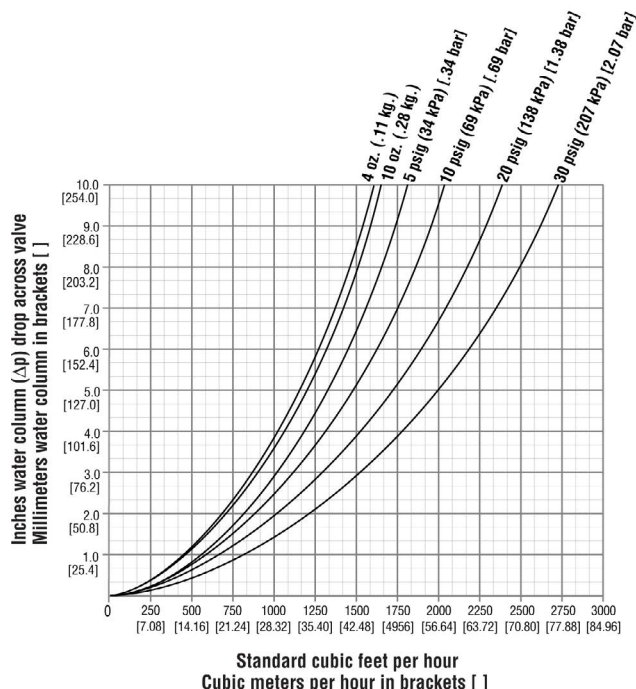

How To Order

Options listed below. All configurations may not be available. Call your sales representative or FW Murphy for more information.

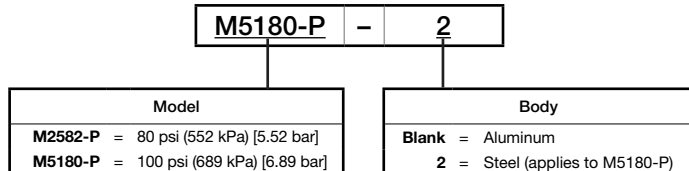

Approximate Shipping Weight	
Model	Weight
M2582-P	5 lbs 10 oz (2.55 kg)
M5180-P	9 lbs 2 oz (4.16 kg)

Part Number	Description	Notes
55000148	Latching Handle Assembly	M2582-P Service Parts
55000147	Stem & Seat Assembly	
55000150	Top Works Complete Valve Less Body & Vent Repair Kit	
55000143	Vent Bushing Assembly Kit	
55000184	Diaphragm Assembly Kit	
55000154	Latching Handle Assembly	M5180-P Service Parts
55000155	Top Works Complete Valve Less Body & Vent Repair Kit	
55000132	Vent Bushing Assembly Kit	
55000153	Diaphragm Assembly Kit	

信德迈科技（北京）有限公司2005年开始在中国经销美国Murphy摩菲仪器仪表产品

北京朝阳区望京SOHO-T1-C座2115室 邮编: 100102

手机: 139 1096 2635

电子邮件: sales@cnmec.biz