

Shock and Vibration Switch VS2™ Series

The VS2 Series switches are shock-sensitive mechanisms for shutdown of engine or electric motor powered equipment. It is designed to detect shock/vibration in three planes of motion.

These fully adjustable switches use a magnetic latch to ensure reliable operation. Explosion-proof EX models for hazardous locations are available.

Ideal for use on engines, pumps, compressors, heat exchangers and pumping units, the VS2 Series can be used where shut-down protection from damaging shock/vibration is desired. Switches are field adjustable to the sensitivity required in each application.

Specifications

Normal Operating Temperature: -40° to 185° F (-40° to 85° C);
For CSA applications, applicable temperature specification is de-rated to -40° to 140° F (-40° to 60° C)

VS2 and VS2C

Case: Environmental Protection: Ingress protected to IP54 when mounted on a horizontal surface with drain holes down. Suitable for non-hazardous locations or as simple apparatus connected to a certified non-incendive or intrinsically safe electrical digital input. VS2C: C-clamp mount, includes 45 ft. (13.7 m) 2-conductor cable and 5 cable clamps.

Contacts: SPDT-double make leaf contacts, 3A @ 240 VAC; 10A @120 VAC; 10A @ 32 VDC

Shipping Weight: VS2: 2 lb. 8 oz. (1.1 kg); VS2C: 7 lb (3.2 kg)

Shipping Dimensions: VS2: 8-1/4 x 9-1/4 x 5 in. (210 x 235 x 127 mm); VS2C: 12 x 7 x 5-1/2 in. (305 x 178 x 140 mm)

VS2EX

Case: Base mount, explosion-proof aluminum alloy housing; meets IP54 specifications; Class I, Division 1, Groups C & D hazardous locations

Certification: CSA for Canada and US

Snap switches: 2-SPDT snap switches; 5A @ 480 VAC; 2A resistive, 1A inductive, up to 30 VDC

Shipping Weight: 4 lb. 8 oz. (2 kg)

Shipping Dimensions: 8-1/4 x 9-1/4 x 5 in. (210 x 235 x 127 mm)

VS2EXR

Case: Same as VS2EX

Certification: CSA for Canada and US

Snap switch: 1-SPDT snap switch and reset coil; 5A @ 480 VAC; 2A resistive, 1A inductive, up to 30 VDC

Remote Reset: 115 VAC or 24 VDC (specify)

Shipping Weight: 5 lb. 8 oz. (2.2 kg)

Shipping Dimensions: 8-1/4 x 9-1/4 x 5 in. (210 x 235 x 127 mm)

VS2EXRB

Case: Explosion-proof aluminum alloy housing; designed to meet Class I, Division 1, Group B hazardous areas

Certification: No third-party certification

Snap switch: 1-SPDT snap switch with reset coil (option available for 2-SPDT switches); 5A @ 480 VAC; 2A resistive, 1A inductive, up to 30 VDC

Remote Reset: 115 VAC or 24 VDC (specify)

Shipping Weight: 17 lb. 8 oz. (7.9 kg)

Shipping Dimensions: 12 x 12 x 10 in. (305 x 305 x 254 mm)



All trademarks and service marks used in this document are the property of their respective owners.

Basic Operation

Pushing the reset button moves the tripping latch into a magnetically held position. A shock/vibration will move the magnet beyond this holding position, thus freeing the spring loaded tripping latch to transfer the contacts and shut down the machinery (see dimensional diagrams or visual representation of parts).

Remote Reset Operation (VS2EXR and VS2EXRB)

The remote reset option includes a built-in electric solenoid which allows reset of tripped unit from a remote location, or hold-in reset during starting. Available for 115 VAC or 24 VDC.

Dimensions

Environmental Protection: Ingress protected to IP54 (when mounted on a horizontal surface with drain holes down).

VS2 and VS2C

The VS2 and VS2C are designed for use in non-hazardous locations. They have leaf type SPDT, double make contacts that can be used for shutdown and/or alarm. They have a slotted sensitivity adjustment located on the side of the case (see drawing).

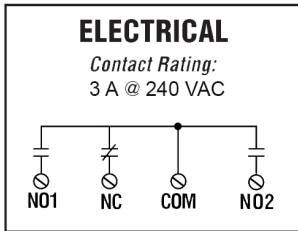
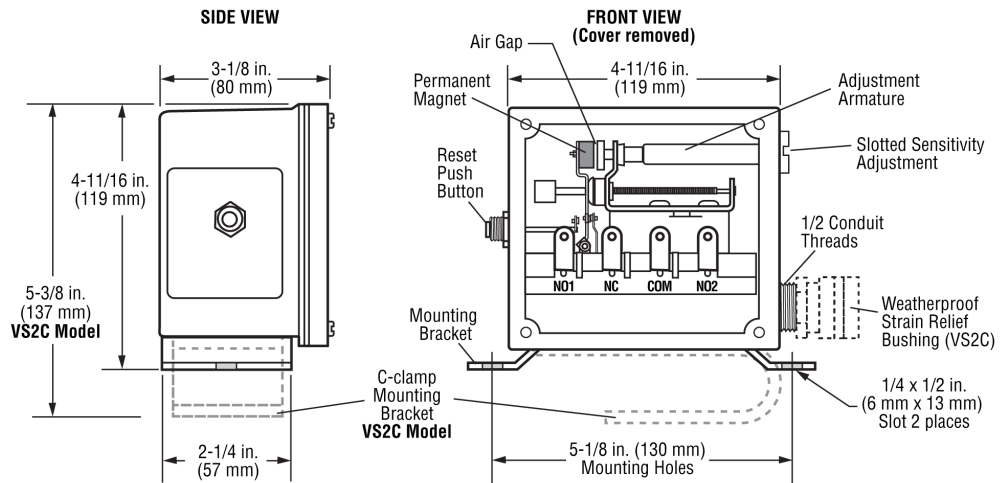

VS2EX

- IP54 specifications
- Snap switch contacts
- Reset button

Model VS2EX is housed in an explosion-proof enclosure with threaded cover. This enclosure is CSA for Canada and US, listed for Class I, Division 1, Groups C & D hazardous locations. In place of the leaf type contacts, 2-SPDT snap-switches are used in this model. Sensitivity is externally adjustable, and when tripped, the VS2EX gives indication on the reset button. It is constructed to meet IP54 specifications.

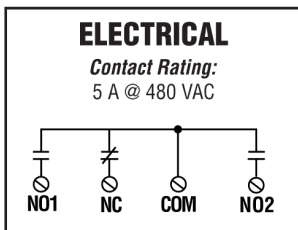
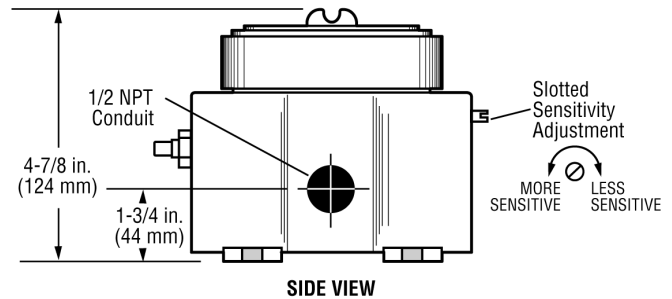
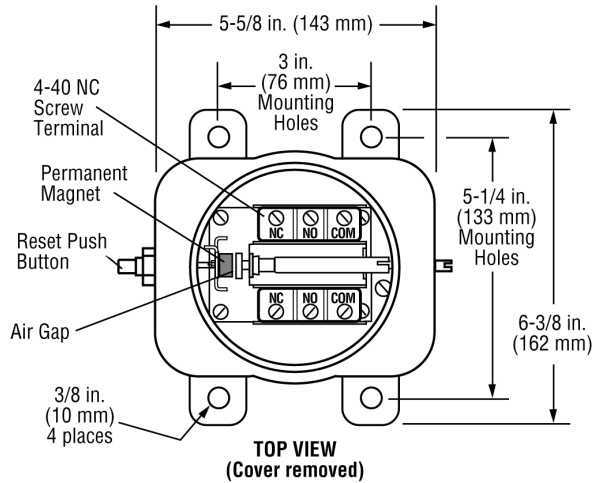

Dimensions - continued

VS2EXR

- Remote reset feature
- IP54 specifications
- Snap-switch contacts
- Reset button

Model VS2EXR features an electric remote reset feature in addition to the reset button. The VS2EXR uses only one SPDT snap-switch and is CSA for Canada and US, listed for Class I, Division 1, Groups C & D hazardous locations. It is constructed to meet IP54 specifications.



ELECTRICAL

Contact Rating:

5 A @ 125-480 VAC
 1/2 A @ 125 VDC
 1/4 A @ 250 VDC
 2 A Resistive 30 VDC
 1 A Inductive 30 VDC

Remote Reset Rating:

115 VAC or 24 VDC (Specify)
 350 mA AC/DC

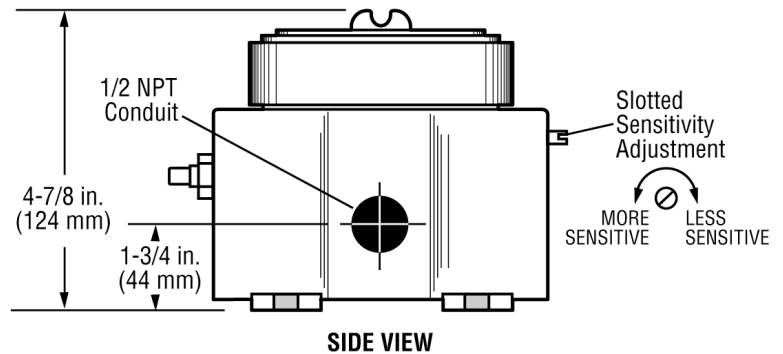
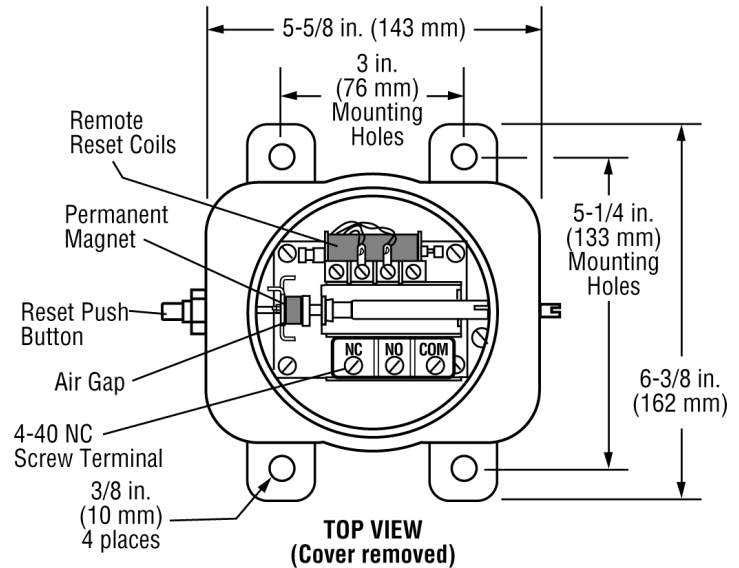
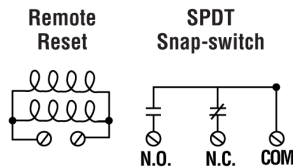

VS2EXRB

- For Group B locations (not certified)
- Snap-switch contacts
- DPDT feature optional

Model VS2EXRB is constructed for use in Class I, Division 1, Group B, hazardous locations. It has as standard a SPDT snap-switch and an electric remote reset. Option is available for DPDT snap-switch

ELECTRICAL

Contact Rating:

5 A @ 125-480 VAC
 1/2 A @ 125 VDC
 1/4 A @ 250 VDC
 2 A Resistive 30 VDC
 1 A Inductive 30 VDC

Remote Reset Rating:

115 VAC or 24 VDC (Specify)
 350 mA AC/DC

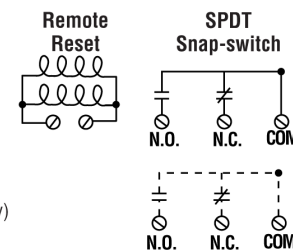

Option SPDT Snap-switch (DPDT)

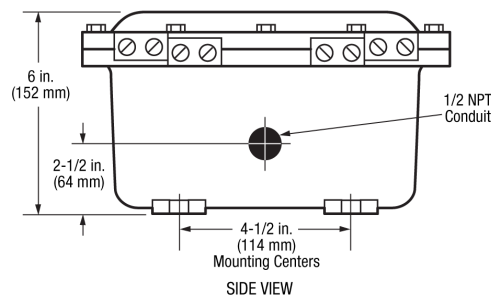
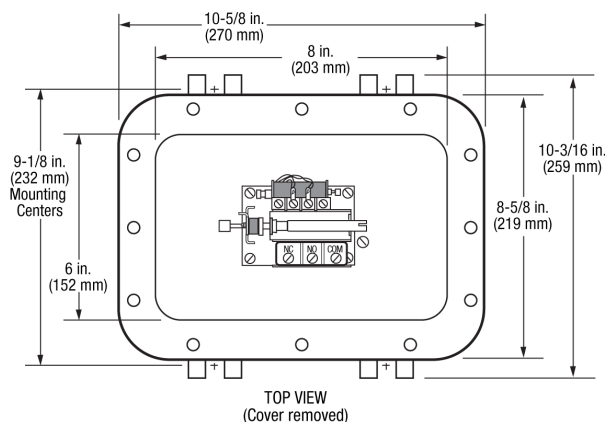

Recommended Use

This device is a passive mechanical switch for use in non-hazardous areas. It may be used in hazardous areas with an FW Murphy Controller approved for hazardous areas equipped with a non-incendive or intrinsically safe digital input circuits, when Installation Diagrams are followed for that Controller. This device will meet the intent of a general-purpose passive mechanical switch associated with the Controller's hazardous area approvals. When used in an intrinsically safe circuit, the end device and associated wiring must meet the entity parameters for the circuit.

How to Order

Options listed below. All configurations may not be available. Call your sales representative or FW Murphy for more information.

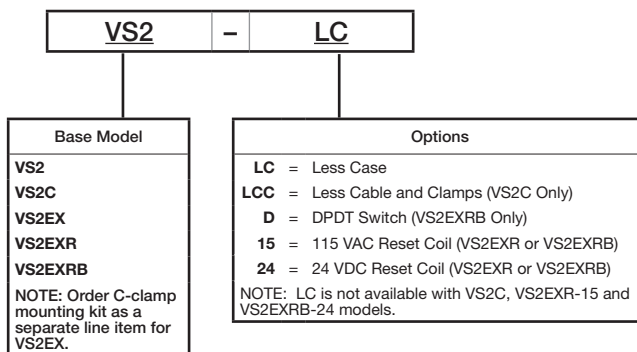

Service Part Number	Description	Notes
20000031	Glass and gasket assembly	VS2 and VS2C
20000032	Reset push button assembly	
20000261	Cable clamp assembly with hardware (1 each)	VS2C
20000288	Snap-switch and insulator kit (1 switch per kit)	VS2EX
20000289	C-clamp conversion mounting kit	
25050506	Dust boot assembly	

北京卡梅逊控制技术有限公司【信德迈科技（北京）有限公司】

2005年开始在中国经销美国Murphy摩菲仪器仪表产品:

地址: 北京朝阳区望京SOHO-T1-C座2115室 邮编: 100102

手机: 139 1096 2635 电子邮件: sales@cnmec.biz

网站: <http://www.cnmec.com>